

REV	ZONE	REVISION	DATE

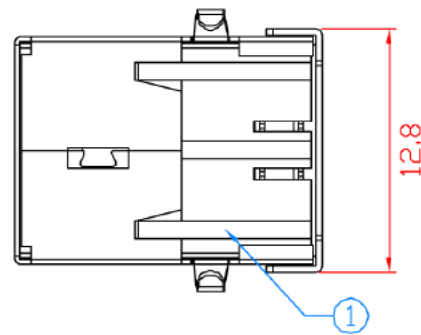

Specification:
 Contact Resistance: 30m Ohm Max.
 Insulation Resistance: 1000M Ohm Min. At 500VDC.
 Rated Voltage And Current: 1.5A At 250VAC Minimum.
 Dielectric Withstanding Voltage:
 500V AC (rms) for 1 Minute(Rev. 2.0)
 Durability (Life Test): 1500 Cycles
 Insertion Force: 35 Newton Maximum.
 Extraction Force: 10 Newton Minimum.

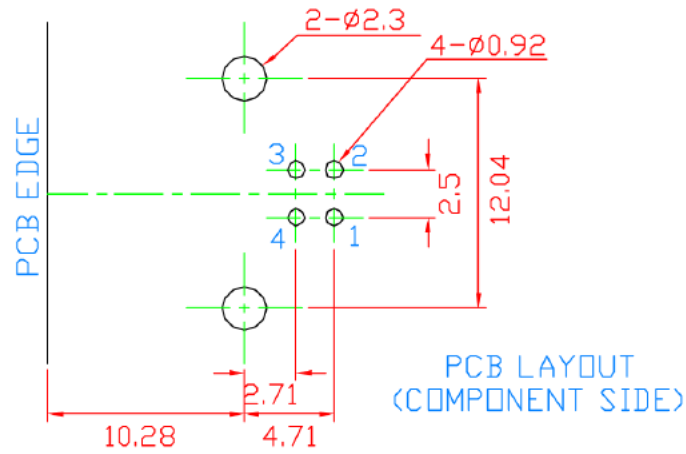
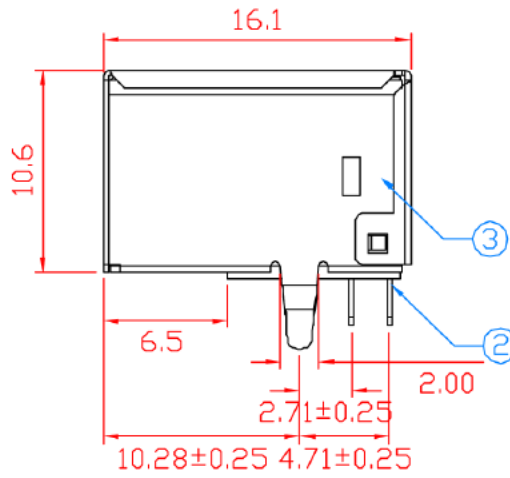
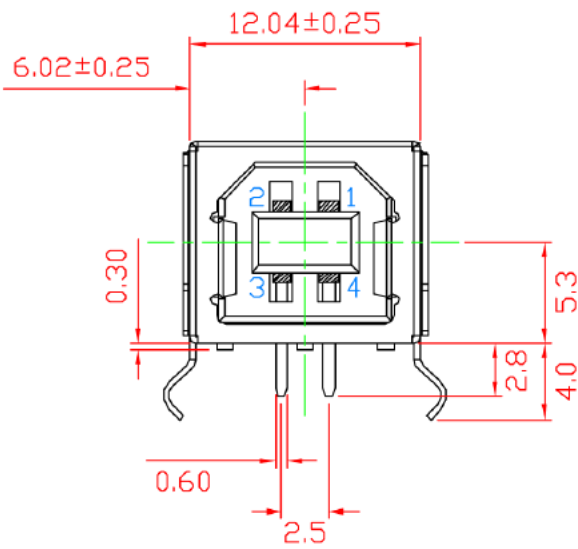

NO.	NAME	MATERIAL	FINISH	REMARK	Q'TY
1	HOUSING	PBT G.F.	WHITE		1
2	PIN TERM.	PHOS. BRONZE T:0.25	GOLD/TIN PLATED	Gold:30u" Ni:40-60u" TiNi:120u" (100% pure Tin of lead free plating)	4
3	SHELL	BRASS T:0.3	NICKEL PLATED	Ni:80-120u"	1



COMPUTER NO.			UNIT	SCALE	PART NAME	
USBS-BT1-W-2.0-R			mm	1:1	USB B TYPE FLAT 4 PIN DIP	
APPD.	CKD.	DWG.	DATE	TOLERANCE	PART NO.	REV.
		TINA	05-03-10	X. ±0.38 .X ±0.25 .XX ±0.13 .XXX ±0.05	USBS-BT1-W-2.0-R	A0