

RECOMMENDED PANEL CUTOUT

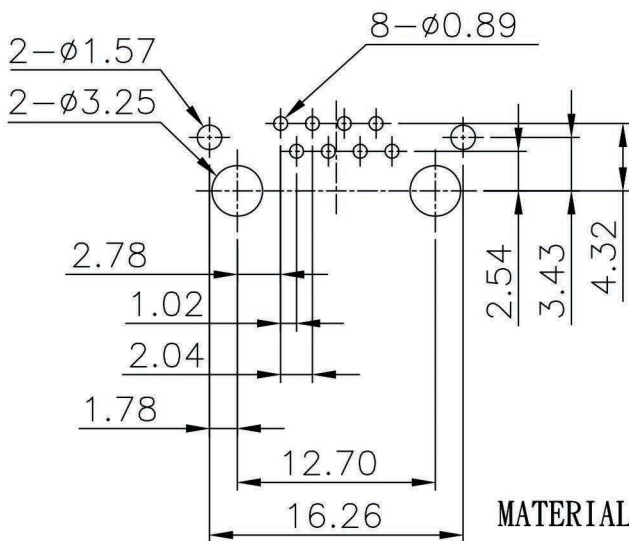

MATERIALS:

PLASTIC HOUSING: ENGINEERING THERMOPLASTIC
FLAMMABILITY RATING UL 94V-0.

CONTACTS: PHOSPHOR BRONZE

PLATING: GOLD PLATING OVER NICKEL IN CONTACT, 6µ"

TIN PLATING OVER NICKEL IN SOLDER AREA.

SHIELD: BRASS PLATING TIN/LEAD ALLOY.

ENVIRONMENTAL:

OPERATING TEMPERATURE: 0° C TO +70° C.

STORAGE TEMPERATURE: -40° C TO +80° C.

修正 REVISION	日期 DATE	容許公差 TOLERANCE	品名 ARTICLE	RJ45 8P8C JACK SHIELED		
		.XXXX ----	圖號 DWG NO.	MTC-8810STU-R		
		.XXX ±0.13	單位 UNIT	比例 SCALE	張數 SHEET	版次 REV.
		.XX ±0.25	mm	2/1	1/1	A
		.X ±0.38	核准 APPD.			
			校對 CHKD.			
			設計 DR. Kathy	91-05-07		