

ROHS COMPLIANT

REV.	DESCRIPTION	ECN NO.	DWN.	CHK.	APVD.	DATE
A			XIE			2011-04-22

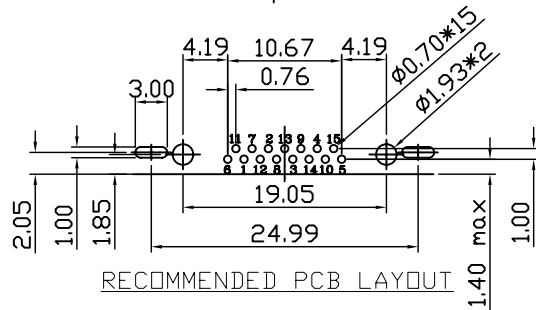
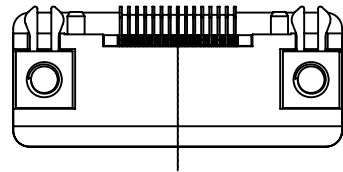
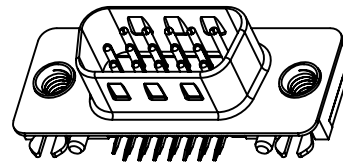
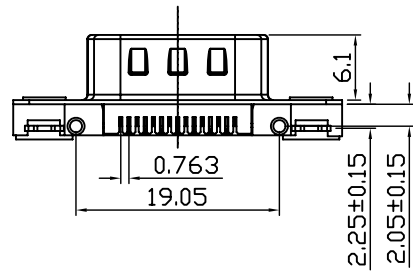
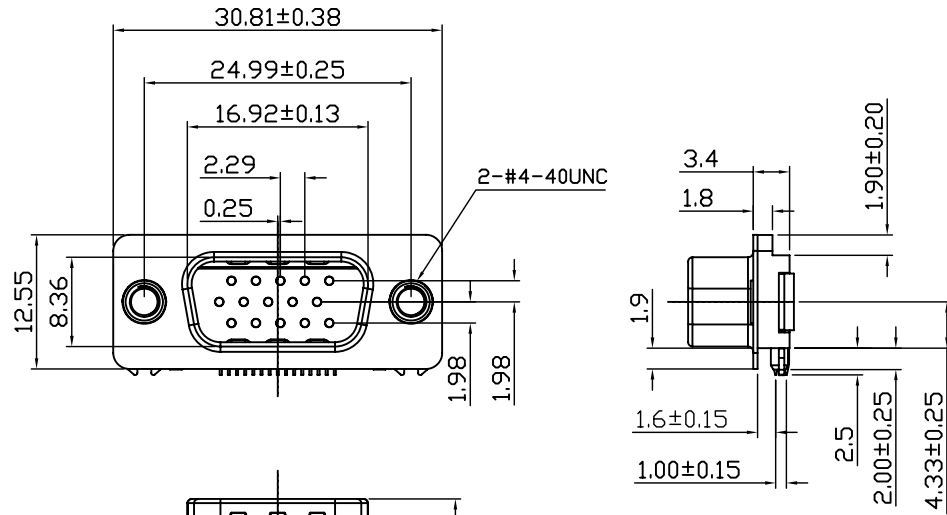

SPECIFICATIONS

ELECTRICAL CHARACTERISTICS:

Contact Current Rating:3 Amperes.
 Dielectric Withstanding Voltage:
 AC 1000/60sec.r.m.s.
 Insulation Resistance:5000 Medohms
 Minimum.at DC 500V.
 Contact Resistance:25 Milliohms Maximum.
 Operating Temperature:-55°C to+105°C.

MECHANICAL CHARACTERISTICS:

Contact Insertion Force:341 g.Maximum.
 Contact Separation Force:21 g.Minimum.



MATERIALS:

Contacts:Brass.
 Insulator:Glass-Filled Thermoplastic Blue
 PBT,UL94V-0
 Shell:Cold Roller Steel.

FINISHES:

Contact: Gold Flash.
 Shell: Nickel Plated.
 Boardlock : Brass, Tin Plated.
 Clinch Nut : Brass, Nickel Plated.

DO NOT SCALE DRAWING

DIMENSIONS: <input type="checkbox"/> MM [INCH] <input type="checkbox"/> INCH [MM] <input checked="" type="checkbox"/> MM ONLY		CAD GENERATED DRAWING, DO NOT MANUALLY UPDATE		 GTK UK Ltd
UNLESS OTHERWISE SPECIFIED, GENERAL TOLERANCE: DECIMALS ANGLES .X ±0.38 [0.015] X° ±3° .X ±0.25 [0.010] .X° ±1.0° .XX ±0.13 [0.005]		DRAWN BY AND DATE TIAN PEI FU 2011-04-22		
MATERIAL:		CHECKED BY AND DATE JACK CHEN 2011-04-22		DRAWING NO. HDLS15PTBL1NS-R
FINISH:		APPROVED BY AND DATE FRANKY CHEN 2011-04-22		REV A
		THIRD ANGLE PROJECTION 		FILE NO.:
		SCALE: 1 : 1	SIZE: A3	SHEET 1 OF 1