

DESCRIPTION CONTROL			
REV	DESC	DATE	APP

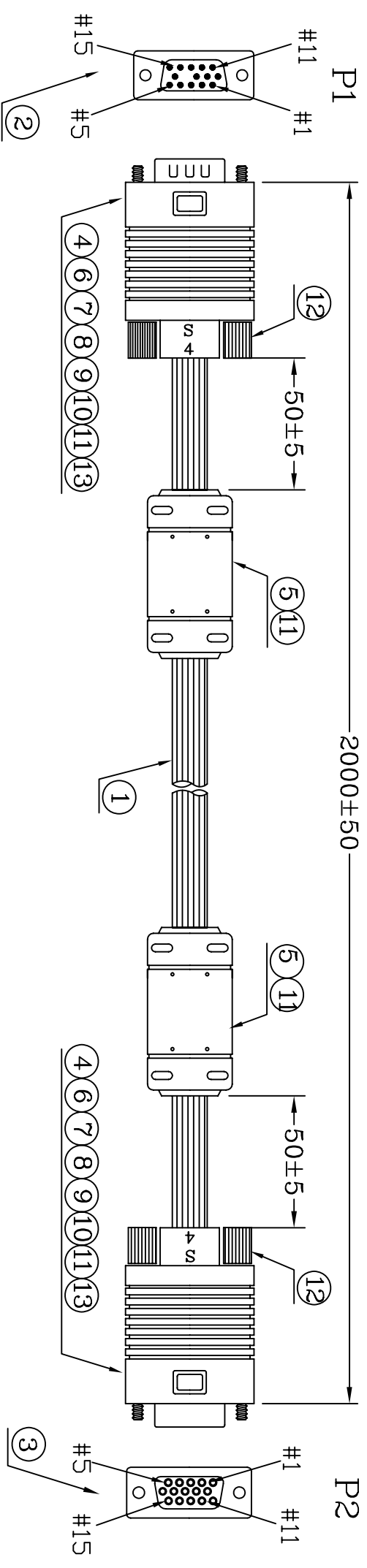

NOTE:
 1. CABLE COLOR : BLACK(BK10#).
 2. 馬口鐵需360°環焊.

ROHS COMPLIANT

PIN ASSIGNMENT	
P1	P2
1	1
2	2
3	3
4	4
5	5
6	6
7	7
8	8
9	9
10	10
11	11
12	12
13	13
14	14
15	15
S	S

*	390	TIE-A100/BK	1	PCS
13	210	TAPE:W:12MM L:40MM	2	PCS
12	370	SRW-Q39.6/BK10	4	PCS
11	370	PVC-BK10/50	70	G
10	370	SDL-WIRE-FULL-TIN-12	30	G
9	370	DB9PIN馬口鐵(一件式,OD:9.5MM)	2	PCS
8	370	PE-5321	80	G
7	220	SDL-WIRE-FULL-TIN-10	0.8	G
6	210	TUBE-HT-φ3.0*8MM	6	PCS
5	210	CORE:17.5*27*9.5MM	2	PCS
4	210	TUBE-HT-φ1.0*12MM	6	PCS
3	220	CDS-HISS<BK>(第9PIN不插PIN)	1	PCS
2	220	CDS-HISP<BK>-9	1	PCS
1	210	UL2919-3CDAX*28#+8C*26#+ADB-BK10-2M-φ8.5 (齒狀)	1	PCS

DESCRIPTION	QTY	UNIT	390	CARTON:46*30*25CM	1/50	PCS
TIE-A100/BK	1	PCS	390	CARTON:46*30*25CM	1/50	PCS
TAPE:W:12MM L:40MM	2	PCS	390	PE BAG:30*28*0.08MM	1/50	PCS
SRW-Q39.6/BK10	4	PCS	390	PE BAG:7*10*0.06MM	1	PCS
PVC-BK10/50	70	G	390			
SDL-WIRE-FULL-TIN-12	30	G				
DB9PIN馬口鐵(一件式,OD:9.5MM)	2	PCS				
PE-5321	80	G				
SDL-WIRE-FULL-TIN-10	0.8	G				
TUBE-HT-φ3.0*8MM	6	PCS				
CORE:17.5*27*9.5MM	2	PCS				
TUBE-HT-φ1.0*12MM	6	PCS				
CDS-HISS<BK>(第9PIN不插PIN)	1	PCS				
CDS-HISP<BK>-9	1	PCS				
UL2919-3CDAX*28#+8C*26#+ADB-BK10-2M-φ8.5 (齒狀)	1	PCS				



ITEM: MA1515300001048

DRAW, BY: LYJ
 CHECK, BY:
 APP, BY:
 SCALE: ENDO
 DATE: 2003/10/24

ALL DIMENSIONS IN mm